



TT-65

THERMOTWEEZ HANDPIECE

PAGE P/N 7025-0001

OPERATION & MAINTENANCE

INSTRUCTIONS

MANUAL NUMBER 5050-0336

REV. B

PACE Incorporated retains the right to make changes to specifications contained herein at any time, without notice.

Contact your local authorized PACE Distributor or PACE Incorporated to obtain the latest specifications.

The following are registered trademarks and/or servicemarks of PACE Incorporated, Laurel Maryland U.S.A. and may only be used to identify genuine PACE products or services:

AdapTip, Arm-Evac, Cir-Kit, ComForm I, ConducTweez, CRAFT, Dual Path, EKO, Flo-D-Sodr, FuseSet, HandiPik, HotSpot, LapFlo, MBT, Micro Portable, MicroChine, MiniChine, Pacenter, PACE, Ped-A-Vac, PETS, PIK-VAC, PRC, PRINT, Pro-Evac, Redi-Rak, ResistTweez, SensaTemp, SMR, SNAP-VAC, Sodr-Pen, Sodr-X-Tractor, SR-3, SR-4, ST, StripTweez, SwaPlater, ThermoBand, ThermoJet, ThermoPart, ThermoPik, ThermoTweez, Thermo-Drive, Tip-Evac, VisiFilter.

The following are trademarks and/or servicemarks of PACE Incorporated, Laurel Maryland U.S.A. and may only be used to identify genuine PACE products or services:

Mini-Wave



Since 1958, PACE Incorporated has provided training in all aspects of hand soldering, rework and repair.

Additional copies of this manual or other PACE literature may be obtained from:

PACE Incorporated	(301) 490 - 9860
Sales Administration	(301) 4983252 Fax
9893 Brewers Court	
Laurel MD 20723-1990	



These instructions detail the basic operational guidelines for using the TT-65 ThermoTweez handpiece. A detailed Operation & Maintenance Manual is available from PACE.

INTRODUCTION

The ThermoTweez handpiece provides safe, one-handed removal of a wide variety of "J" Leaded (PLCC), Leadless (LCCC), SOICs, PQFPs, Bumper Packs (BQFPs), large extended lead (FlatPacks), SMT Connectors and Chip style components in a matter of seconds. The ThermoTweez's low temperature, high capacity heating can remove even the largest components quickly and easily. The ThermoTweez is a member of the PACE SensaTemp family of advanced SMT/Thru-Hole soldering/desoldering handpieces and works with any PACE SensaTemp power source.

CAUTION

Always use this handpiece in a well ventilated area. A fume extraction system such as the PACE Arm-Evac is highly recommended to help protect personnel from solder flux fumes.

NOTE

Remember that the ThermoTweez is primarily a component removal tool. Also, a ThermoTweez Cushion Grip Kit (PACE P/N 6993-0155) is available for applications where the handpiece is under continuous use at high tip temperature settings. This kit provides added comfort to the user.

HANDPIECE SETUP

HANDPIECE ALIGNMENT

Check the handpiece heaters for proper alignment with each other. Proper handpiece (and tip) alignment is essential for effective operation.

1. Remove any installed tip halves.
2. **With the handpiece at room temperature**, adjust the Heaters parallel to each other using the Tip Gap Adjustment Thumb Screw. If the heater ends are even with each other, go to "Power Source Connection". If the ends are not even, go to step 3.
3. Loosen the handpiece Hinge Screw 1/2 turn.
4. Holding the handpiece in a vertical position (heaters facing down), place the ends of the two Heaters against a hard flat surface to insure proper alignment. The Heater ends should be even with each other and flush against the flat surface. Gently push the rear of the handpiece handles to force both Heaters against the flat surface.
5. Retighten Hinge Screw to secure in position.

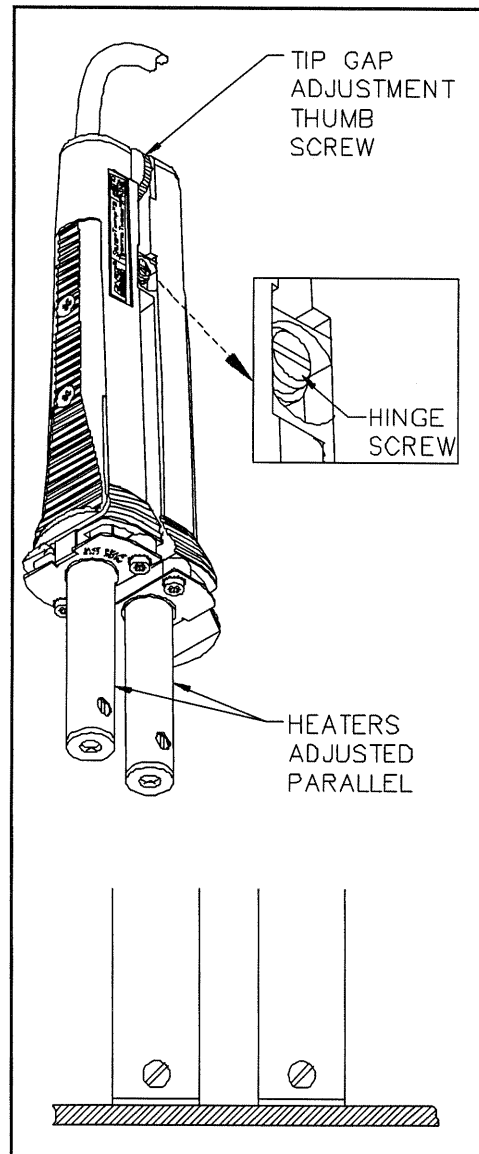

POWER SOURCE CONNECTION

Connect the handpiece power cable connector to one of the front panel power receptacles on your PACE power source. PACE recommends that air handpieces utilize the power receptacles closest to the **SNAP-VAC** (or **VACUUM** or **VACUUM OPTION**) and Controllable **PRESSURE** Ports to minimize cord tangles. The ThermoTweez (which does not require air to operate) is normally connected to the center or left side receptacles.

NOTE

To insure optimum performance, use only 1 ThermoTweez and any other SensaTemp handpiece on 2 channel power sources. On MBT 250/220 systems, 2 ThermoTweez handpieces may be powered by the same power source with the third channel left vacant (no handpiece connected).

TIP TEMPERATURE

If using your ThermoTweez for the first time or if you have just replaced the heater, we recommend that you follow the “Heater Burn-in” procedure (Red tag on handpiece) to increase the life expectancy of the heater.

The TT-65 efficiently transfers heat by contact and typically allows component removal at relatively low temperatures in the 288 - 343°C (550 - 650°F) range. Tip temperature and removal times will vary with each application. PACE recommends the use of a 316°C (600°F) tip temperature setting for initial use in any particular application. With practice, many components can be removed at lower temperatures. Use the lowest possible tip temperature that will provide rapid, yet controlled solder reflow. Lower temperatures extend tip and heater life, allow solder to remain on the lower surfaces of the tip (to improve thermal linkage between the tip and the component during component removal) and help prevent possible board damage.

Refer to the Tip & Temperature Selection System booklet for your particular handpiece/tip combination. For all Dial Display SensaTemp systems, the booklet will indicate the correct Dial Setting for the True Tip Temperature desired. On systems incorporating a Digital Readout, set the desired operating temperature and Tip Offset Constant for the TT-65 handpiece/tip combination into the channel powering the TT-65.

TIP SELECTION

Selection of the proper tip is essential for effective operation. Attempts to use an improperly sized tip is likely to result in unsatisfactory handpiece operation and may result in lifted lands or board damage. Select the proper tip for your application.

The following table details a partial listing of available tips. Contact your local authorized PACE distributor for the latest Tips & Accessories Catalogue which details all available tips and accessories.

NOTE

If you do not have the proper tip, call PACE or your local authorized PACE distributor for assistance. Custom tips are available on request.

PLCC (or PQFP) Removal Tip	DESCRIPTION (including lead count)	TIP SIZE A x B	PART NUMBER
<p>TIP</p>  <p>Application</p>  <p>PLCC</p> <p>These ThermoTweezer tips can also remove leadless components (LCCs) with the same lead counts.</p>	PLCC-18	0.34" x 0.23" (8.64mm x 5.84mm)	1121-0314
	PLCC-20	0.27" x 0.27" (6.86mm x 6.86mm)	1121-0316
	PLCC-28	0.37" x 0.37" (9.4mm x 9.4mm)	1121-0317
	PLCC-28R	0.49" x 0.29" (12.4mm x 7.4mm)	1121-0492
	PLCC-32	0.48" x 0.38" (12.2mm x 9.65mm)	1121-0352
	PLCC-44 PQFP-84	0.57" x 0.57" (14.5mm x 14.5mm)	1121-0318
	PLCC-52 PQFP-100	0.67" x 0.67" (17.0mm x 17.0mm)	1121-0319
	PLCC-68 PQFP-132	0.86" x 0.86" (21.9mm x 21.9mm)	1121-0320
	PLCC-84 PQFP-160	1.06" x 1.06" (26.9mm x 26.9mm)	1121-0321
	PLCC-100	1.31" x 1.31" 33.3mm x 33.3mm	1121-0405
<p>PQFP</p> 	PQFP-304	1.64" x 1.64" (41.7mm x 41.7mm)	1121-0491

TABLE I. TIP SELECTION GUIDE





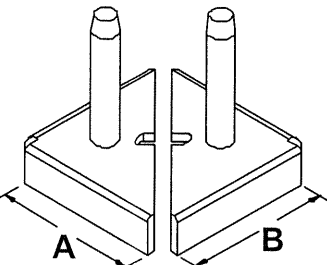
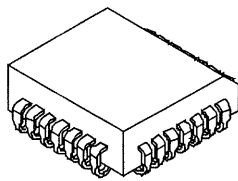
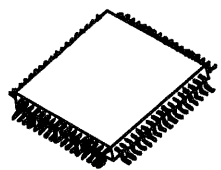

SURFACE MOUNT CHIP COMP. REMOVAL TIPS		DESCRIPTION	TIP SIZE (A)	PART NUMBER
Standard Wall Thickness= 0.050" (1.3mm)		Chip Component (vertical)	A=0.03" (A=0.76mm)	1121-0398
Tip 		Chip Component (vertical)	A=0.08" (A=2.0mm)	1121-0313
Application 		Chip Component (vertical)	A=0.16" (A=4.1mm)	1121-0399
Tip 		Chip Component (vertical) Small SOIC	A=0.25" (A=6.4mm)	1121-0401
Application 		45° Angle Chip Component	A=0.10" (A=2.54mm)	1121-0436
Thin-Wall: Thickness = 0.017" (0.43mm)		Thin-Walled Chip Component (vertical)	A=0.03" (A=0.76mm)	1121-0520
Tip 			A=0.08" (A=2.0mm)	1121-0521
Application 			A=0.16" (A=4.1mm)	1121-0522
Tip 			A=0.25" (A=6.4mm)	1121-0523
Tip 		SOIC, SOJ/SIMMS Component (thin-walled tips)	A=0.50" (A=12.7mm)	1121-0473
Application 			A=0.70" (A=17.8mm)	1121-0416
SIMMS Module			A=0.80" (A=20.3mm)	1121-0497
Application 			A=1.00" (A=25.4mm)	1121-0448
Application 		Narrow-body connectors & SOIC Components	A=0.30" (A=7.6mm)	1121-0512
Tip 			A=0.40" (A=10.2mm)	1121-0514
Tip 		1/64" Angled Fine Point Conical Chip Component	A = .017" (A = 0.43mm)	1121-0517
Application 				

TABLE I. TIP SELECTION GUIDE CONT'D

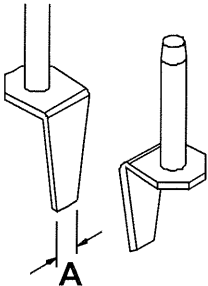
	DESCRIPTION	TIP SIZE A x B	PART NUMBER
<p>LCCC Removal Tips</p>  <p>Application LCCC</p>	<p>LCCC Packages (thin-walled tips) (reduced height = 0.2" for high mass boards)</p>	0.26" x 0.26" (6.6mm x 6.6mm)	1121-0450
		0.35" x 0.25" (8.89mm x 6.35mm)	1121-0452
		0.35" x 0.35" (8.89mm x 8.89mm)	1121-0454
		0.85" x 0.85" (21.6mm x 21.6mm)	1121-0455
<p>Motorola Pager Tips</p>  <p>Application LCCC</p>	<p>Removal of Motorola Pager LCCC Packages (thin-walled tips) (standard height = 0.275")</p>	0.26" x 0.26" (6.6mm x 6.6mm)	1121-0417
		0.28" x 0.28" (7.11mm x 7.11mm)	1121-0419
		0.31" x 0.31" (7.87mm x 7.87mm)	1121-0421
		0.32" x 0.32" (8.13mm x 8.13mm)	1121-0423
		0.40" x 0.35" (9.16mm x 8.89mm)	1121-0425
		0.52" x 0.52" (13.2mm x 13.2mm)	1121-0427
<p>TIP</p>  <p>Application Surface Mount Connector</p>	<p>Surface Mount Connectors</p>	A = 1.25" (A = 31.8mm) Extended Blade Height	1121-0495
		A = 1.5" (A = 38.1mm)	1121-0475
		A = 2.0" (A = 50.8mm)	1121-0477

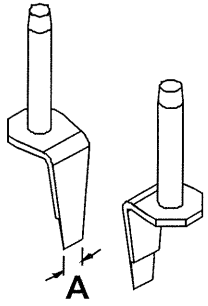
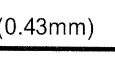
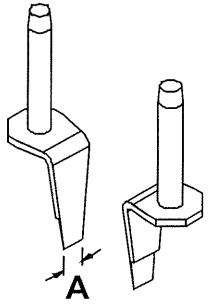
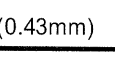
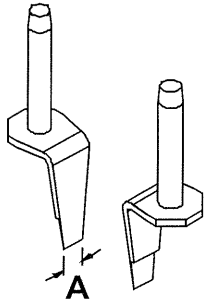
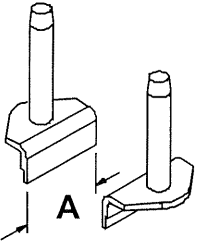
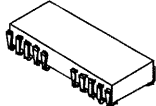
TABLE I. TIP SELECTION GUIDE CONT'D

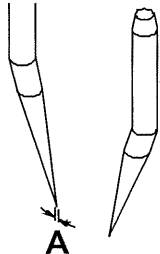
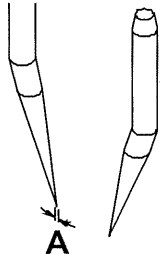
TIP INSTALLATION

The following instructions are for tip installation only. If a tip is currently installed in the handpiece, remove the installed tip (heater hot) and clean the heater bore using the supplied 3/16" diameter wire brush prior to the installation of a new tip.

1. Tips should be installed when the heaters are hot. Turn your power source ON and set the temperature for the channel powering your handpiece to an appropriate temperature (315°C (600°F) is recommended for initial use). Place the handpiece in a ThermoTweez Hot Cubby (PACE P/N 6019-0035) when not in use.

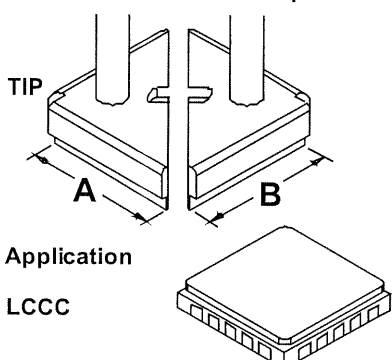
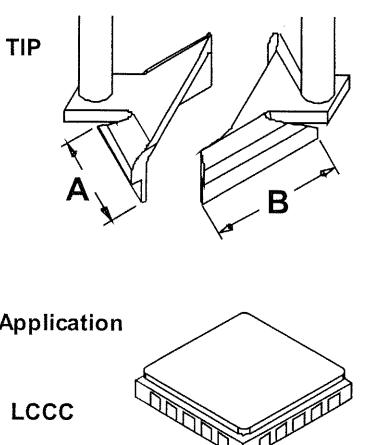
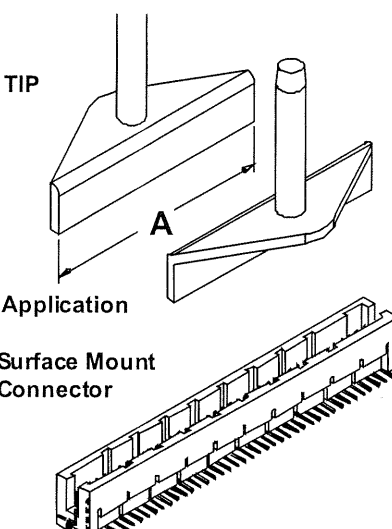
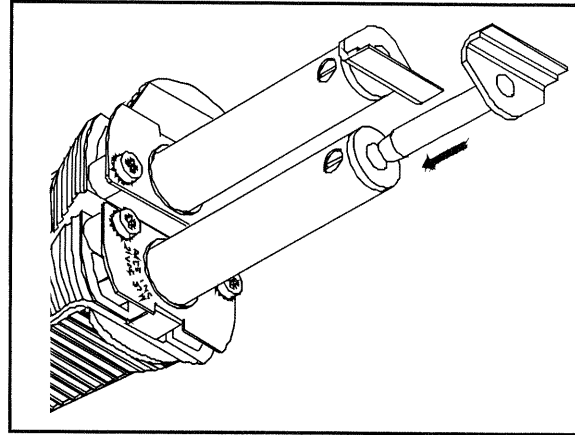

2. Select the proper tip for your application. Refer to Table I or the Tip & Temperature Selection System booklet.

NOTE Selection of the proper tips is essential for successful repair. If you do not have the proper tip, call PACE or your local authorized PACE distributor for assistance. Ask for a copy of the PACE Tip & Applications Catalog for the latest listing of available tips. Custom tips are available on request.

3. Each ThermoTweez tip consists of two identical halves. With the handpiece at the desired temperature, hold the handpiece with the heater ends pointing up at an angle. Insert the shaft of one tip half fully into one of the ThermoTweez handpiece heaters. Insert the shaft of the second tip half fully into the other heater.

NOTE If you like, the heater set screws may be tightened very slightly to hold the tip halves in position while they are being aligned.

4. There are three basic methods for aligning your tips in the ThermoTweez handpiece depending on tip size and type. Tips should be above solder melt temperature prior to performing the alignment procedure. Follow the appropriate procedure (a, b, or c) to install and align the ThermoTweez tip properly.

a) **Small PLCC Tips (no slots) and Chip Component Tips:**

1. Position the tip ends as shown.
2. Squeeze the handpiece closed to press the tip ends together.
3. Holding the handpiece closed, adjust the tip ends as necessary so that they meet precisely together.
4. Gently tighten the heater set screws to secure the tip halves in position.

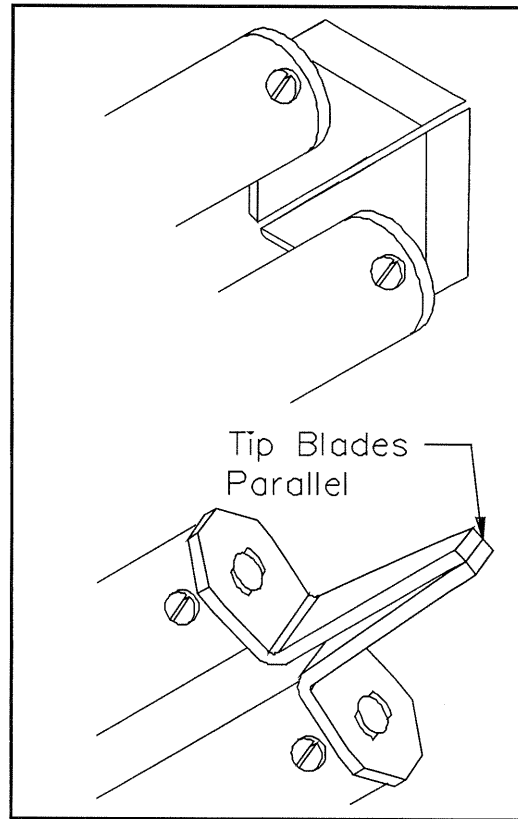

- b) **Large PLCC Tips (with slots):**
Large PLCC tips (PLCC 44 lead count or higher) have a small slot cut into the diagonal edge of each half.

1. With the tip halves oriented as shown, insert the supplied Tip Alignment Tool between the two tip halves and position the Alignment Blocks of the tool into the tip slots as shown.
2. Squeeze the handpiece closed to grip the Tip Alignment Tool tightly between the two tip halves.
3. Tighten the heater set screw on each heater using the tip tool or a small blade screwdriver to secure tip into position.

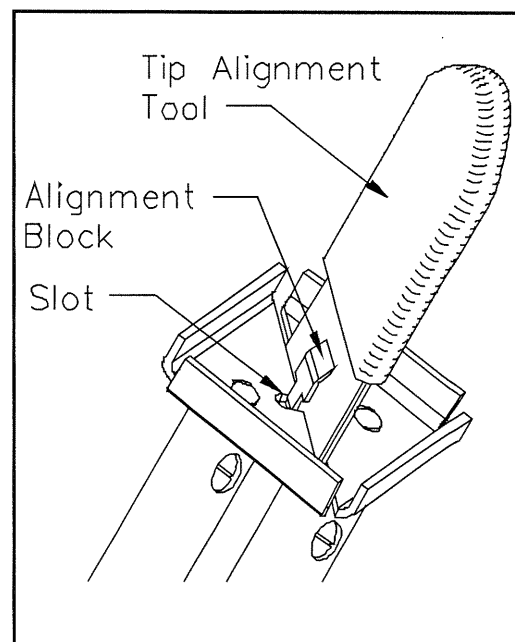

c) **SOIC, SOJ/SIMMS Tips & Surface Mount Connector Tips:**

1. Position the tip halves as shown.
2. Using the tip gap adjustment thumb screw at the rear of the ThermoTweez handpiece, increase the space between the tip halves to allow insertion of the Sponge Tool or Fiber Tool from the Tip Maintenance Station (PACE P/N 6993-0138).

NOTE

The Tip Tool may also be used for this purpose.

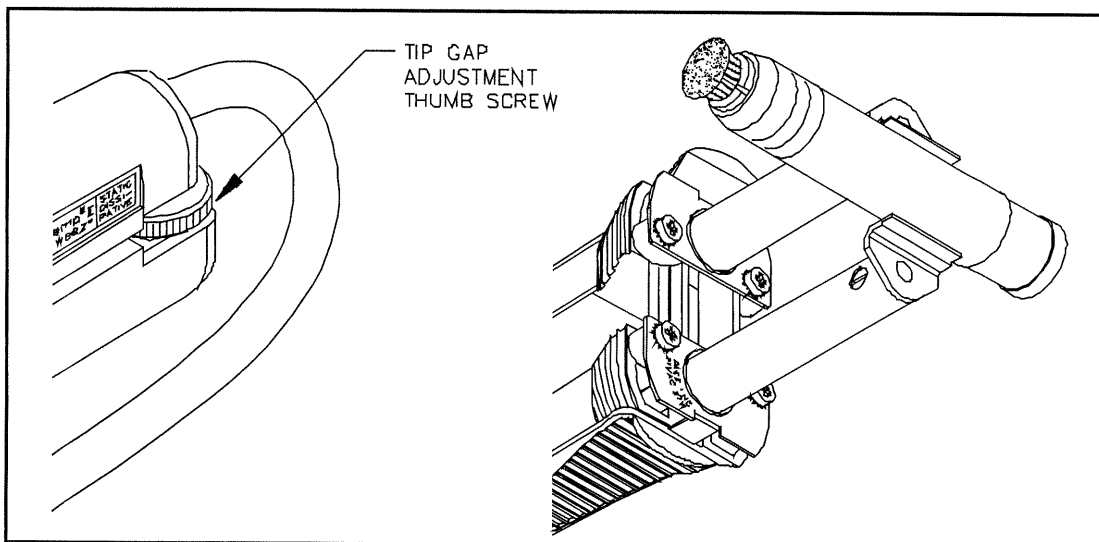

3. Position the Sponge Tool or Fiber Tool between the tip halves as shown.
4. Squeeze the handpiece closed with the tip ends pressed firmly against the Sponge Tool or Fiber Tool.
5. Gently tighten the heater set screw on each heater using the tip tool or a small blade screwdriver to secure tip into position.

TIP PREPARATION

Always follow the procedure below for each component removal operation and prior to storage of the handpiece in the hot cubby. Proper preparation will insure optimum results and increase tip life.

NOTE

The use of a PACE Tip Maintenance Station (P/N 6993-0138) is recommended for the proper preparation and maintenance of all ThermoTweez tips. If this item has not been purchased, contact your local authorized PACE distributor for assistance.

1. Insure that the installed tip has reached the set tip temperature.

2. Use the fiber tool found in the Tip Maintenance Station to remove all solder dross and excess solder from the inside edges of the tip. PACE recommends placement of the tip over the moistened sponge area of the Tip Maintenance Station to catch solder and dross removed from the tip.

3. Wipe the inside edges of the tip using the sponge cleaning tool or the sponge area of the Tip Maintenance Station.

NOTE

Insure that the sponge material is moist.

4. Use a large gauge solder to tin each of the tip lower inside edges.

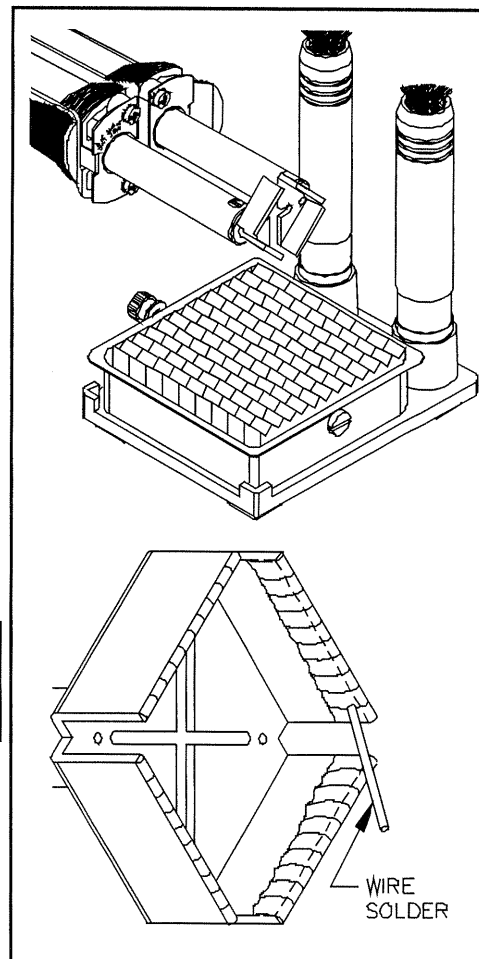

PCB/COMPONENT PREPARATION

Proper preparation is the key to successful component removal. To obtain optimum results, follow these steps while adhering to all requirements of your organization's guidelines (e.g., EOS/ESD control program, temperature limits, approved cleaning procedures).

1. Examine the component and pcb (printed circuit board) for any signs of conformal coatings, oxides or contamination. If any are found, remove using an appropriate means approved by your organization.
2. Clean the component leads and pcb (printed circuit board) land area using an approved solvent or cleaner.
3. Insure that the pcb (printed circuit board) is free of moisture. You may wish to gently dry the land area using a heated air tool (e.g., PACE Mini ThermoJet handpiece).
4. Preheat the pcb (printed circuit board) as necessary. Many substrates such as ceramic and polyamide, as well as those incorporating large ground planes or multilayer technology, should be preheated.
5. In order to maximize heat transfer from the handpiece tip to the component lead/land connections on PLCCs, FlatPacks, PQFPs and LCCCs, PACE recommends the

adding of solder.....

solder preforms

or

solder paste

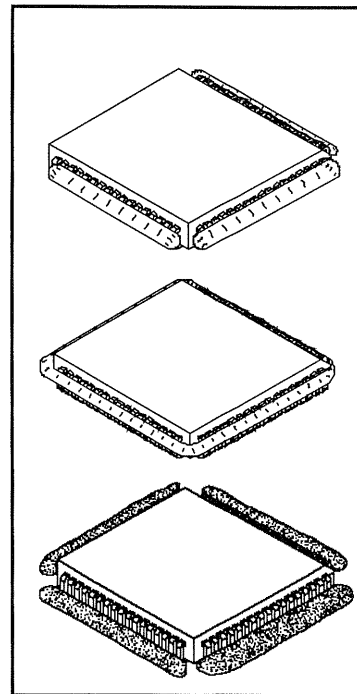

to effectively create solder bridges across all connections. Once you become familiar with the use of the handpiece, you may find it beneficial to develop procedure variations which comply with your company guidelines.

COMPONENT REMOVAL

Use the following procedure to remove the component. Ensure that the ThermoTweez tip, and the component to be removed have been properly prepared (see “Board/Component Preparation”) before removing component. The handpiece (and installed tips) should be operating at the desired set tip temperature.

1. Set the pcb (printed circuit board) so that the component side to be worked on is flat and steady.
2. Apply a small amount of flux (approved for use by your company) to the component lead/land areas.
3. Using the tip gap adjustment thumb screw, close the two halves so that they just clear the leads of the component. This slip fit adjustment will then allow the tip to slide down over the component while providing maximum adjacent component clearance.
4. Clean the tip and apply a fresh bead of solder to all tip surfaces.

5. Hold the ThermoTweez handpiece in a vertical position (tip down) directly over the component to be removed.
6. Lower the tip down over the component joint areas. You may find it necessary to adjust the tip halves slightly using the tip gap adjustment thumb screw. Be careful not to contact the pcb with the tip.
7. Gently squeeze the handpiece closed to grip the component and ensure even contact between the tip and the component leads or terminations.

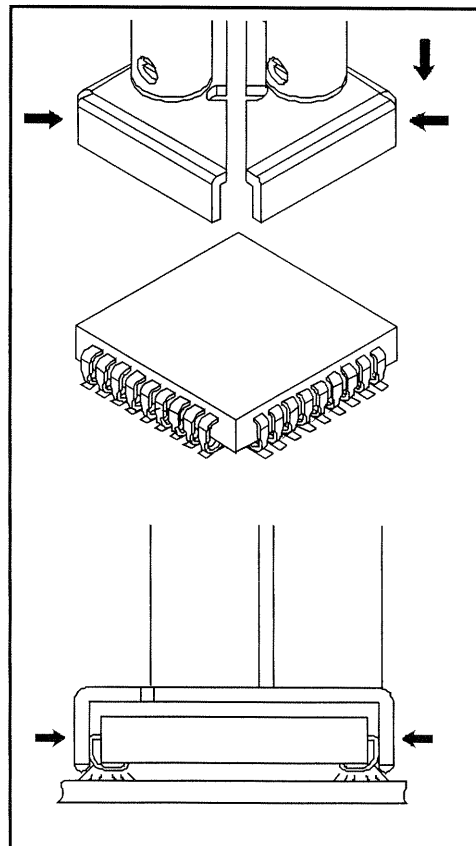

8. Complete reflow of all the solder joints should occur in a short time. When reflow of all solder joints is observed, either visually or by the component yielding to a very gentle sliding or rotational movement, lift the handpiece along with the component from the pcb.

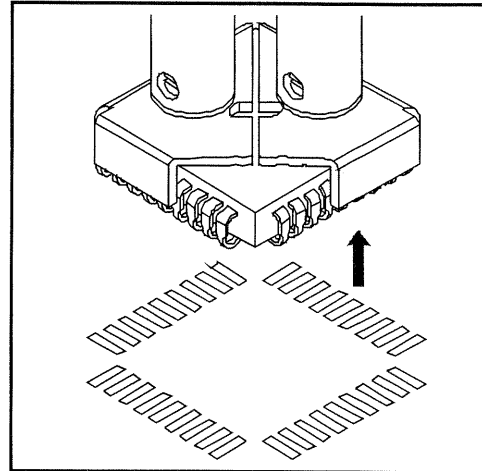

CAUTION

PCB damage may occur if the handpiece is lifted prior to reflow of ALL solder joints. If you don't get complete reflow of all the solder joints in several seconds, release the component, rotate the handpiece (and installed tip) 90° and try again (step 7). If you still don't achieve complete solder melt quickly, try bridging the leads with solder, solder preforms or solder paste (see "PCB/Component Preparation") or increase tip temperature (within your organization's guidelines). Also, preheating may be required if the board is multilayer or has ground planes. See "PCB/Component Preparation".

9. Release pressure on the handpiece to release component. Place the component onto a metal or other burn resistant surface. If the component does not release, use the tip gap adjustment thumb screw to open the tip halves slightly.
10. After component removal, always clean and retin the tip with a flux core solder prior to returning the handpiece to its hot cubby.
11. Clean land pattern of residual solder using the PACE SX-70 Sodr-X-Tractor handpiece. Refer to either of the SX-70 Sodr-X-Tractor Handpiece Manuals (5050-0312 or 5050-0334).

SPECIAL APPLICATIONS

If you require assistance in the use of this handpiece or require assistance with a special application, contact PACE Applications Engineering at:

Telephone: (301) 490-9860

Fax: (301) 604-9215

CORRECTIVE MAINTENANCE

Use Table II and the illustrations to determine the cause of malfunctions to your ThermoTweez handpiece. Disconnect the handpiece from the power source; use a voltmeter to check resistance across the handpiece Connector Plug pins as outlined in the Heater Assembly Checkout Procedure.

CAUTION

The handpiece must be at room temperature when performing the Checkout Procedure to prevent potential burns to the technician. Additionally, all readings have been determined from the cold handpiece.

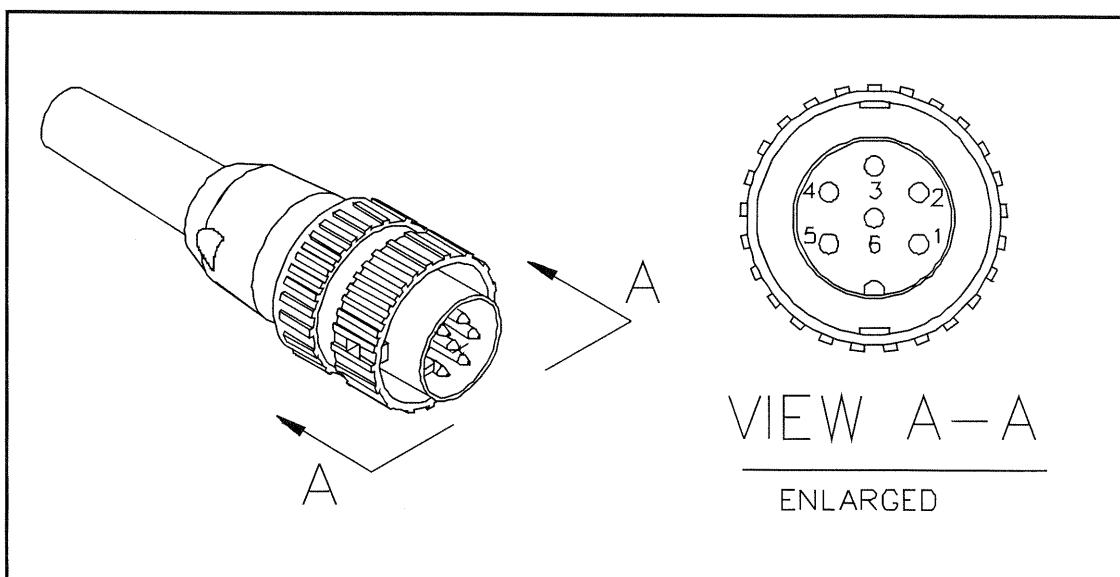

SYMPTOM	CHECKOUT PROCEDURE	CAUSE	SOLUTION
No heat on either heater.	Check resistance - Pin 3 to Pin 6. Resistance should be 110 ohms. If circuit reads open - -	Open Sensor	Replace Heater Assembly "A".
	Check resistance - Pin 2 to Pin 5. Resistance should be 6 ohms. If circuit reads open - -	Open Heater	Replace both Heater Assemblies.
Handpiece overheating.	Check resistance - Pin 3 to Pin 6. Resistance should be 110 ohms. If circuit reads less than 105 ohms - -	Shorted Sensor	Replace Heater Assembly "A".
Heat on only 1 heater.	Check resistance - Pin 2 to Pin 5. If resistance equals 12 ohms - -	Open Heater	Replace cold Heater Assembly.
Fuse blows when unit is turned on.	Check resistance - Pin 4 to Pin 5 and Pin 4 to Pin 2. Circuit should read open. If not - -	Shorted Heater	Remove handpiece side cover "B". Disconnect wire connections to Heater "B". Check resistance again. If circuit reads open, replace Heater "B". If circuit is not open, replace Heater "A".

TABLE II. HEATER ASSEMBLY CHECKOUT PROCEDURES

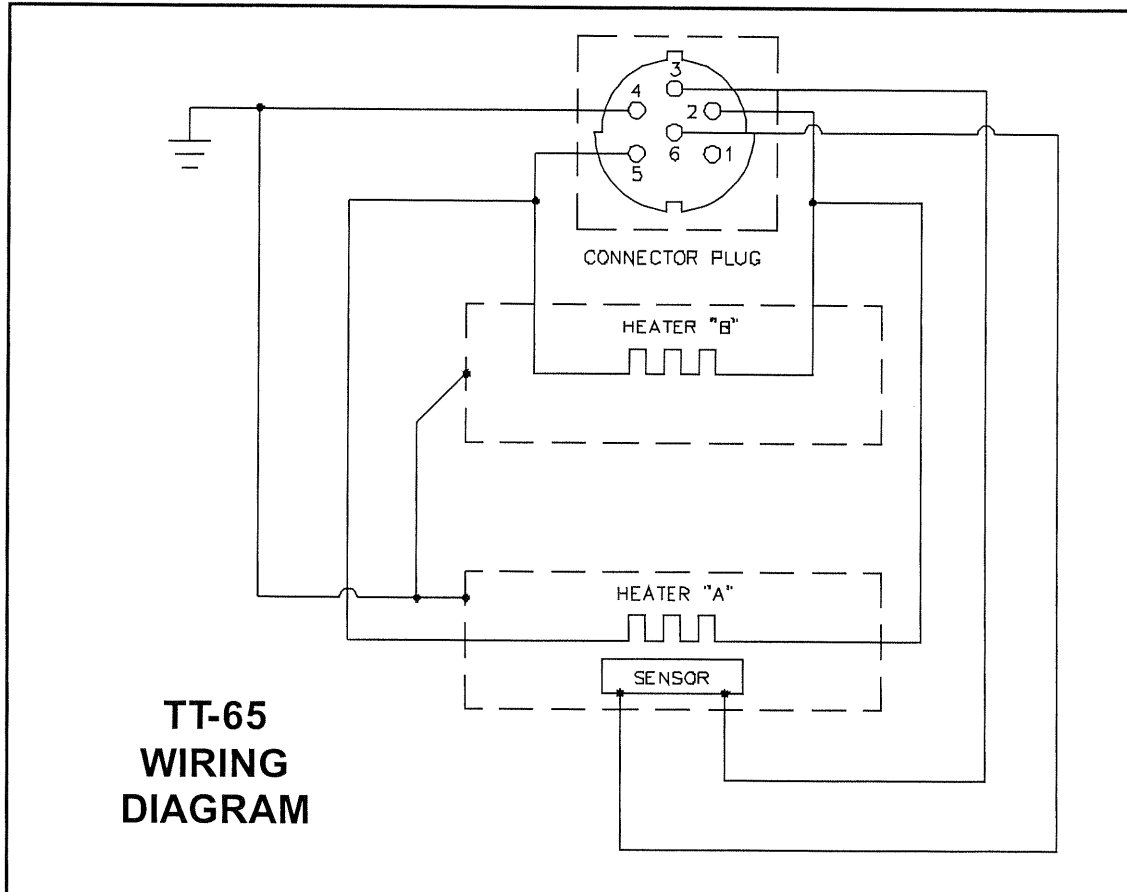

REPLACEMENT PARTS

Table III lists the parts needed to maintain your ThermoTweez handpiece.

Description	Part Number
Heater Assembly "A" (with sensor)	6010-0082-P1
Heater Assembly "B" (without sensor)	6010-0083-P1
Heater Set Screw	1348-0547
Tip Tool	1100-0206
Tip Alignment Tool	1100-0234
ThermoTweez Cubby	6019-0035
Cushion Grip Kit	6993-0155
Replacement Pads For Cushion Grips	1317-0029-P2
Tip Redi-Rak	6021-0007-P1
3/16 inch O.D. Wire Brush For Cleaning	1127-0014-P5
Tip Maintenance Station	6993-0138

TABLE III. REPLACEMENT PARTS

OPERATION

REFERENCE GUIDELINES

The **PULSE HEAT** Output Control reference guidelines listed in the table below are recommended by PACE as base reference parameters only. In each application, **PULSE HEAT** Output Control adjustments may be necessary. Start with the applicable setting listed below and increase output level in small increments until desired results are achieved.



COMPONENT TYPE	OPERATION	# LEADS OR SIZE	TIP USED	TIP OUTLINE	OUTPUT LEVEL	
	REMOVAL	18	1121-0294		7	
		18-DRAM	1121-0372		7	
		20	1121-0295		7	
		28	1121-0296		8	
		32	1121-0348		9	
		44	1121-0297		10	
 PLCC (J LEAD)	REPLACEMENT	18	1121-0298		3	
		20	1121-0298		3	
		28	1121-0300		3	
		44	1121-0299		3	
 EXTENDED LEAD	REPLACEMENT	Sngl. Point	6000-0008		3	
		0.270"	1121-0298			3
		0.540"	1121-0299			3
		0.440"	1121-0300			3
 CHIP COMPONENT	REMOVAL & REPLACEMENT	VARIABLE	1121-0286		5	

Table 5. Pulse Heat Reference Guidelines

OPERATION

CAUTION

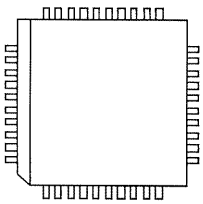
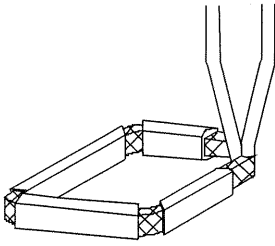
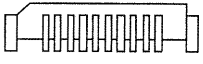
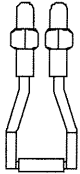
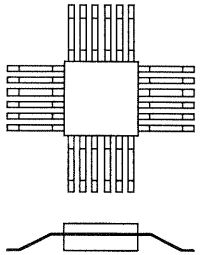
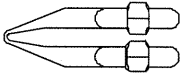
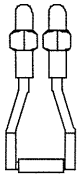
For continuous use, the Output Level settings listed in Table 5 are the maximum recommended values. Exceeding these levels for extended periods may sometimes cause the handle to get hot.

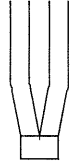
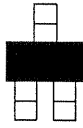
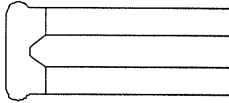
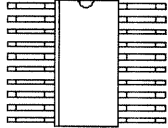
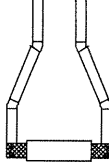
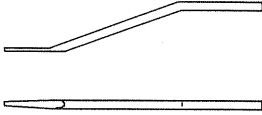
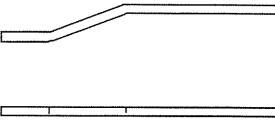
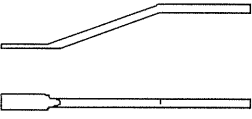
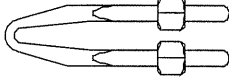

COMPONENT TYPE	OPERATION	# LEADS OR SIZE	TIP USED	TIP OUTLINE	OUTPUT LEVEL
 SOT	REMOVAL & REPLACEMENT	3	1121-0269		7
 SOIC	REMOVAL	8	1121-0269		6
		14, 16	1121-0271		6.5
		20	1121-0270		6.5
		24, 28	1121-0293		6.5
CONNECTOR TERMINAL SOLDERING	REMOVAL & REPLACEMENT	ANY	1121-0301		6
			1121-0009		6
			1121-0006		6
COATING REMOVAL	REMOVAL	POLY U	6000-0009		2
		EPOXY			2.5
WIRE STRIP	REMOVAL	PVC, RBR	1121-0003		2 - 3
		TEFLON			3 - 6

Table 5. Pulse Heat Reference Guidelines Cont'd